



# SERIE 402

## V2RH

BSP / NPTF  
ORB / SAE

INTEVA

Fabricados en acero calibrado.  
Disponibles con o sin taladros de fijación.  
Combinaciones de Roscas disponibles bajo pedido y cantidad mínima.

### • Materiales

Cuerpo: *Acero al carbono EN -10277-3 / AISI 316L / AISI 303*

Tóricas: *NBR, Vitón o EPDM*

Asiento Bola: *P.O.M (Delrin®)*

Maneta: *ZAMAK-5*

### • Temperatura de trabajo (Tóricas)

	NBR	Viton	EPDM
+	+100°C	+200°C	+150°C
-	-30°C	-10°C	-40°C

### • Sectores: Industrial, Agrícola.



• **Aplicaciones:** Diseñado para Aceite Hidráulico. Aplicaciones según la normativa Europea 97.23.EC

### • Equivalencia

PISTER BKH  
MHA BKH  
HYDAC KHB  
DMIC DVH

### REFERENCIA MODELO

Ejemplo;

## 402.1015 AF

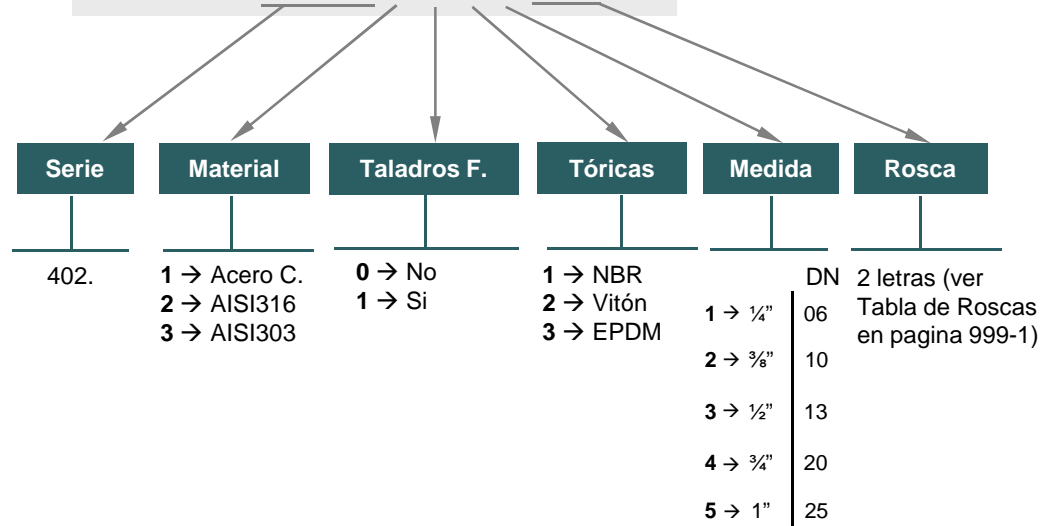

## 402-1







# SERIE 402

## V2RH

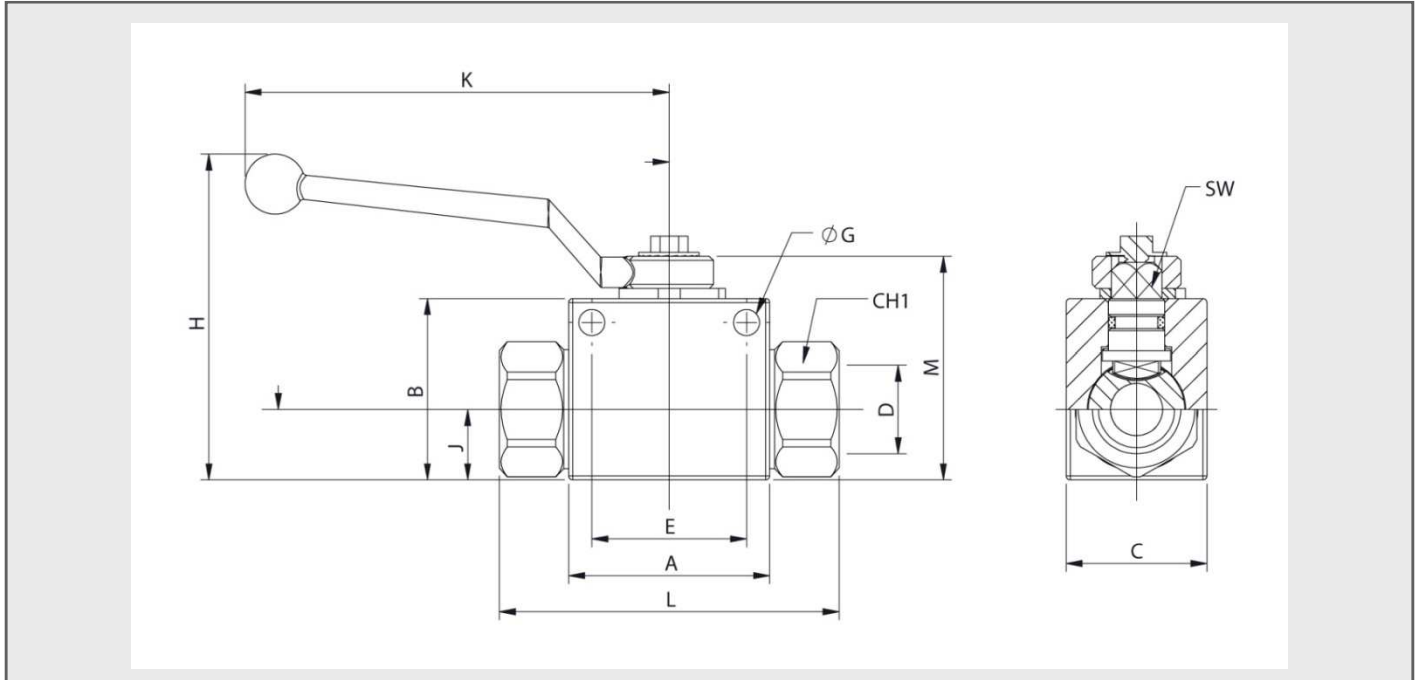
BSP / NPTF  
ORB / SAE



### MODELOS ESTÁNDAR

DN	D	Con A.F.	Sin A.F.		CH1	L	A	B	M	K	H	J	C	SW	G	E
06	1/2" BSP	402.1111AB	402.1011AB	500Bar	22	74,60	40	35	45,50	105,50	71	13	26	8,90	4,50	31,50
	1/4" NPTF	402.1111BB	402.1011BB													
	7/16" - 20ORB	402.1111GA	402.1011GA													
10	3/8" BSP	402.1112AC	402.1012AC	500Bar	27	75,40	45	40	50,50	105,50	76	16	32	8,90	5,20	31,50
	3/8" NPTF	402.1112BC	402.1012BC													
	9/16" ORB	402.1112GC	402.1012GC													
13	1/2" BSP	402.1113AD	402.1013AD	500Bar	30	84,50	50	45	55,50	105,50	81	17,50	35	8,90	6,50	38,50
	1/2" NPTF	402.1113BD	402.1013BD													
	3/4" - 16ORB	402.1113GF	402.1013GF													
20	3/4" BSP	402.1114AE	402.1014AE	400Bar	41	93,40	60	58	73	159,50	108	23	50	13,90	6,50	48,50
	3/4" NPTF	402.1114BE	402.1014BE													
	1 1/16" - 12ORB	402.1114GK	402.1014GK													
25	" BSP	402.1115AF	402.1015AF	350Bar	50	114,50	65	65	80	159,50	115	27,50	57	13,90	8,50	50,50
	1" NPTF	402.1115BF	402.1015BF													
	1 1/4" BSP	402.1115AG	402.1015AG													
	1 1/4" NPTF	402.1115BG	402.1015BG													
	1 1/2" BSP	402.1115AH	402.1015AH													
	1 1/2" NPTF	402.1115BH	402.1015BH													
	1 5/16" - 12ORB	402.1115GO	402.1015GO													

## 402-2





# SERIE 402

## V2RH

Industria  
Minera



Roscas especiales para industria minera  
Fabricadas en acero calibrado.  
Disponible con o sin taladros de fijación.

### • Materiales

Cuerpo: *Acero al carbono EN -10277-3*

Tóricas: *NBR, Vitón o EPDM*

Asiento Bola: *P.O.M (Delrin®)*

Maneta: *ZAMAK-5*

### • Temperatura de Trabajo (Tóricas)

	NBR	Viton	EPDM
	+100°C	+200°C	+150°C
	-30°C	-10°C	-40°C

- **Aplicaciones:** Diseñado para Aceite Hidráulico. Aplicaciones según la normativa Europea 97.23.EC

### • Sectores: Industria minera



### REFERENCIA MODELO

Ejemplo;

## 402.1013 MIN3

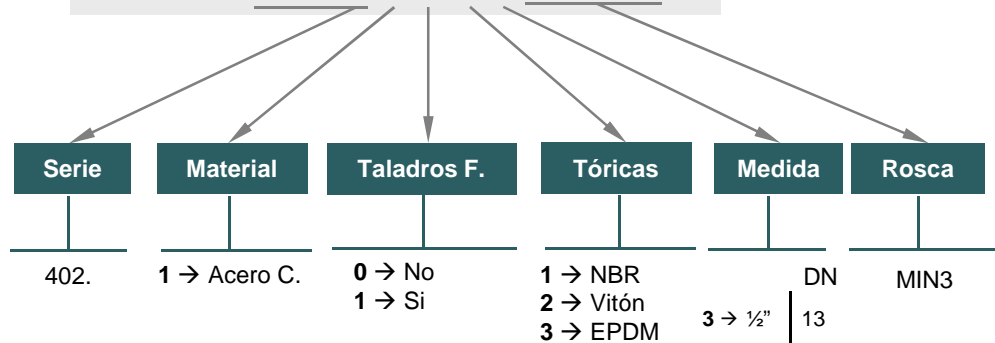

## 402-3





# SERIE 402

V2RH Industria Minera

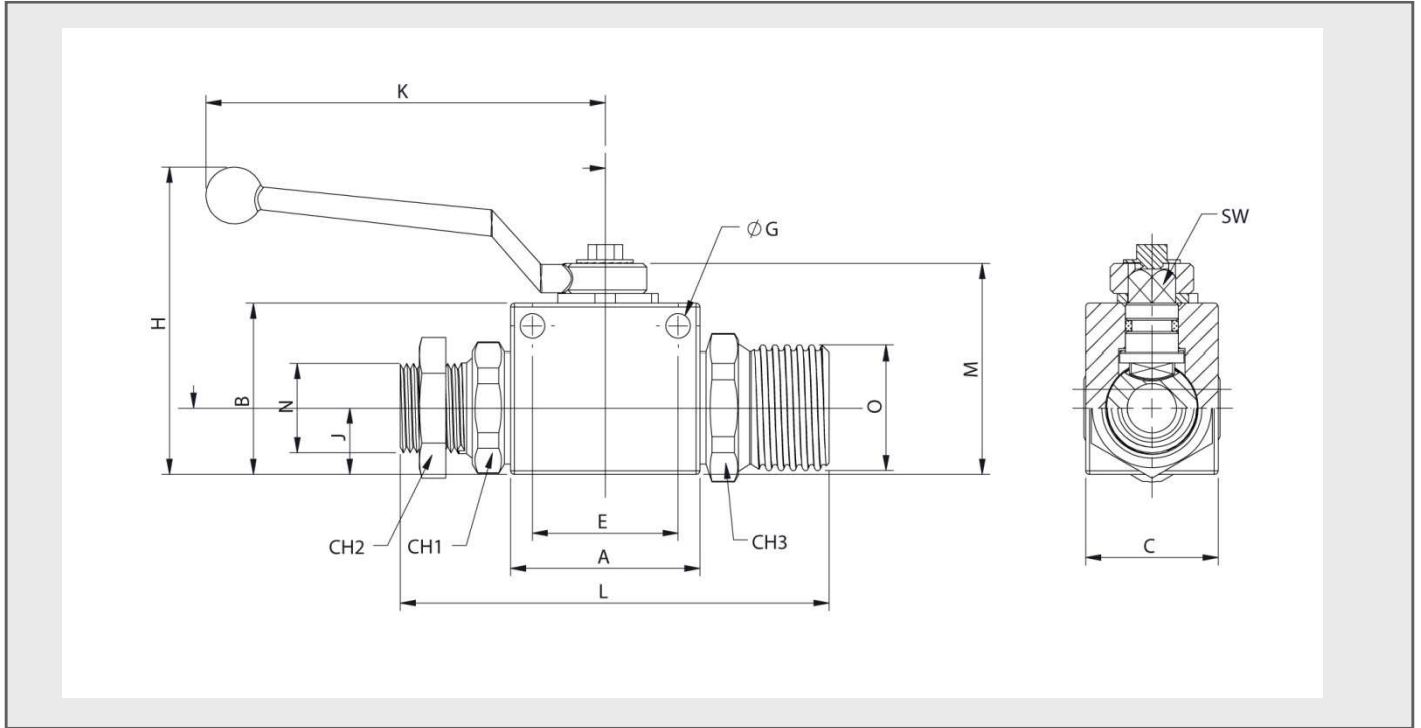

## MODELOS ESTÁNDAR

DN	O	N	Con A.F.	Sin A.F.		CH1	L	A	B	M	K	H	J	C	SW	G	E
13	Rd 33x3,18	<sup>3/4"</sup> (Especial Industria Minera)	402.1013MIN3	402.1113MIN3	500Bar	80	140	100	110	129	214	191	52	100	16,98	*	*

402-4

